

Mitre-Mite®

VN 2+1

Instruction Manual

Version H



TW AMP

Technology for Frame Assembly

100 Fairway Drive Suite 114 Vernon Hills, IL 60061

Phone: 1-800-322-4204

Fax: 1-800-426-7019

INDEX

<u>1. GENERAL INFORMATION</u>	<u>3</u>
1.1 PRODUCER	3
1.2 ASSISTANCE CENTERS	3
1.3 CERTIFICATION	3
1.4 WARRANTY	3
1.5 PRE-ARRANGEMENTS CHARGED TO THE CUSTOMER	3
1.6 HANDBOOK STRUCTURE	3
1.6.1 Object and contents	3
1.6.2 Utilizers	3
1.6.3 Preservation	3
1.6.4 Symbols utilized	4
<u>2. MACHINE DESCRIPTION</u>	<u>5</u>
2.1 WORKING PRINCIPLE	5
2.2 MAIN COMPONENTS	5
2.3 MACHINE STRUCTURE	5
2.4 DIMENSIONS	5
2.5 SURROUNDING CONDITIONS	5
2.6 LIGHTING	5
2.7 VIBRATIONS	5
2.8 NOISE EMISSIONS	5
2.9 TECHNICAL DATA	6
2.10 STANDARD EQUIPMENT	6
2.10.1 Standard accessories	6
2.10.2 Upgrading and implementing of mechanical parts	6
2.10.3 Optional accessories	6
2.10.4 Customized optional accessories	7
2.11 ELECTROMAGNETIC AMBIENT	7
<u>3. SAFETY</u>	<u>8</u>
3.1 GENERAL WARNINGS	8
3.2 SCHEDULED USE	8
3.3 INADVISABLE USE	8
3.4 DANGEROUS AREAS	8
3.5 PROTECTION DEVICES	8
3.6 STOP FUNCTIONS	8
3.7 SAFE WORKING PROCEDURES	8
3.8 RESIDUAL RISKS	9
3.9 PLATES	9
<u>4. INSTALLATION</u>	<u>9</u>
4.1 SHIPPING AND HANDLING	9
4.2 STORAGE	9
4.3 PRELIMINARY ARRANGEMENTS	10
4.4 UNPACKING	10
4.5 CONNECTIONS	10
4.5.1 Pneumatic connection	10
4.6 PRELIMINARY CONTROLS	11
4.7 MACHINE ARRANGEMENT	11
4.7.1 V-Nails magazine loading	11
4.7.2 V-nail guide head replacement to change V-nails size	11
4.8 ADJUSTMENTS	12
4.8.1 V-nails inserting positions adjustment	12
4.8.2 Vertical clamp adjustment	13
4.8.2a Vertical clamp position adjustment	13
4.8.2b Vertical clamp height adjustment	13
4.8.3 Frontal clamp adjustment	13
4.8.4 Working pressure adjustment	14
4.8.5 Protective shield adjustment	15
4.9 CHECKING OPERATIONS TO BE EFFECTED BEFORE WORKING START	15
<u>5. FUNCTIONING</u>	<u>16</u>
5.1 OPERATORS	16
5.2 FUNCTIONING DESCRIPTION	16
5.3 TIPS FOR PERFECT JUNCTIONS	16
5.4 MACHINE STOP	16
5.5 MACHINE REINSTATEMENT	16
5.6 PUTTING OUT OF SERVICE	17
<u>6. MAINTENANCE</u>	<u>17</u>
6.1 STATE OF MAINTENANCE	17
6.2 MACHINE ISOLATION	17
6.3 SPECIAL CAUTIONS	17
6.4 CLEANING	17
6.5 LUBRICATION	18
6.6 ORDINARY MAINTENANCE	18
6.7 EXTRAORDINARY MAINTENANCE	18
<u>7. DIAGNOSTIC</u>	<u>19</u>
7.1 SAFETY WARNINGS	19
7.2 TROUBLESHOOTING	19
7.3 REQUEST OF ASSISTANCE	20
<u>8. SPARE PARTS</u>	<u>21</u>
8.1 SPARE PARTS LIST	21
8.2 SPARE PARTS ORDERING	21
<u>9 DEMOLITION</u>	<u>21</u>
9.1 DEMOLITION	21
<u>10. ATTACHMENTS</u>	<u>21</u>
10.1 DECLARATIONS	21
10.2 SCHEMES	21

1. GENERAL INFORMATION

1.1 PRODUCER

The firm Alfamacchine - ITW/AMP can boast more than 10 years of experience in the construction of Woodworking Machines. It has acquired technological know-how, developed during years of research in strict touch with manufacturing and international commercialization. We offer the best warranty that anyone can grant its customers.

TEL 800-322-4204

FAX 800-426-7019

1.2 ASSISTANCE CENTERS

ITW/AMP is represented both in North & South America by a numerous and prepared sales organization. Contact our firm directly to get the name of your local distributor.

For every need regarding Use, Maintenance or Request of Spare Parts, the Customer is pleased to address to the authorized service centers or directly to ITW/AMP, specifying the machine identification data impressed on the plate.



1.3 CERTIFICATION

The machine is produced in conformity to the pertinent European Community Norms in force at the moment of its introduction on the market.

1.4 WARRANTY

ITW/AMP's products are constructed to have a long life and are tested one by one.

If, in spite of this if any damages or malfunctioning would occur, the replacement of defective parts is warranted (counting from the date written on the delivery bill) for a period of:

- 24 months for mechanical components
- 12 months for pneumatic part

The driver blade is tested for about 1.000.000 working cycles. The Warranty does not include the sending of technical staff. The repair interventions will be performed at your local distributor or ITW/AMP's plants and the freight of the shipment will be entirely charged to the Customer.

Warranty does not cover the damages caused by an inappropriate use of the machine or not corresponding to the instructions described in this handbook.

The warranty decays in case of unauthorized modifications or because of accidental damages or tampering performed by unqualified personnel.

The warranty also decays in case you use V-nails different from the original ITW/AMP ones.

To take advantage of warranty services it is necessary at the moment you receive your machine, to completely fill out the warranty card and send it back as soon as possible to ITW/AMP. The warranty will be valid only after the ITW/AMP receives the warranty card & records it.

1.5 PRE-ARRANGEMENTS CHARGED TO THE CUSTOMER

It is the customer's duty on times agreed with the producer to execute what is indicated in our documentation.

Things normally charged to the customer are:

- Premises predisposition, included building works and/or canalization eventually requested
- Pneumatic supplying of compressed air (see the paragraph 4.5)

1.6 HANDBOOK STRUCTURE

The customer must pay extreme attention to the indications reported in this handbook. The proper Pre-Arrangement, Installation and Use of the Machine, constitute the basis of a correct customer-distributor relationship.

1.6.1 Object and contents

The goal of this handbook is to provide to the customer all the necessary information so that they can properly use the machine & be able to run it in complete autonomy and safety. The handbook contains information concerning the technical aspects, machine working and standstill, maintenance, spare parts and safety. Before making any operation on the machine, the qualified technicians and operators must carefully read this handbook. In case of doubt about the correct interpretation of these instructions, ask ITW/AMP or your local distributor to have the problem explained.

1.6.2 Utilizers

This handbook is made both for the operators and technicians authorized to perform the machine maintenance.







The operators can not execute operations reserved to the the qualified technicians.

The producer does not answer to damages derived from not-observing this prohibition

1.6.3 Preservation

The instruction handbook must be kept very closed to the machine in a special container protecting it from liquids and whatever could compromise its legibility

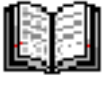
1.6.4 Symbols utilized

 P...	DANGER	It indicates a danger with a mortal risk for the operator
 A...	WARNING	It indicates a warning or a note about key functions or useful information. Pay the maximum attention to the paragraph marked with this symbol.
 O...	OBSERVATION	It is requested to take a measurement data, to check a signal,....
 I...	INQUIRY	The user is requested to check the proper positioning of any element of the machine, before operating a certain command
 C...	EXAMINATION	It's necessary to consult the handbook before performing a certain operation
 R...	ADJUSTMENT	In case of strange situation and/or anomalies you can be requested to perform a certain mechanical adjustment

2. MACHINE DESCRIPTION

2.1 WORKING PRINCIPLE

The benchtop Frame Assembling Machine Mitre-Mite VN 2+1 has been realized to assemble any kind of frame.

The Miter-Mite VN2+1 being of simple construction and extremely easy to use, makes it possible to join with absolute precision any kind of moulding by means of special steel V-nails.

It uses v-nails with the “pulling power” effect in different sizes.

2.2 MAIN COMPONENTS

The main components constituting the machine are:

Pneumatic clamping device to allow a proper locking of the mouldings to insert several V-nails in different positions

Magnetic pressure pads of several types, at quick replacement, to have the proper clamping of any profile

Dual function foot pedal for the separate control of the clamping and nail insertion

Pneumatic opening of the V-nail magazine for a very quick reloading

Nail heads sizes 7, 10 and 15 mm.

2.3 MACHINE STRUCTURE

The movement directions during the machine’s working are the following:

- X AXIS
Movement of the horizontal clamp
- Y AXIS
Movement of vertical clamp

Picture 2.1 A - Movement directions

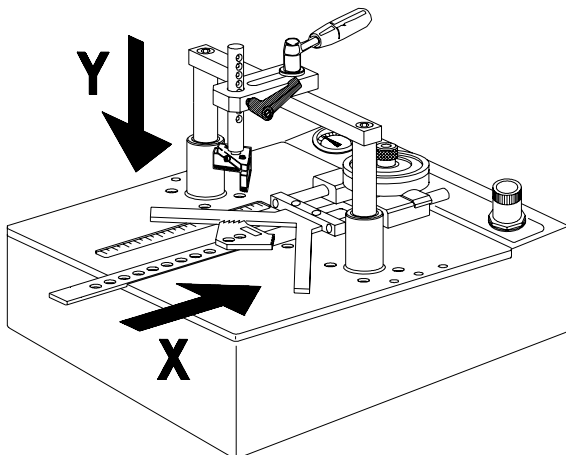

2.4 DIMENSIONS

The overall dimensions are reported on table 2.9-A

2.5 SURROUNDING CONDITIONS

The machine does not need special surrounding conditions. It has to be installed inside an industrial building, lit, aired and with a compact and flat floor. The permitted temperatures go from 41° to 104° F, with a humidity level not higher than 50% at 104° F or 90% at 68° F.

2.6 LIGHTING

Premises lighting must be conformed to the norms in force in that Country where the machine is installed and has to guarantee a clear visibility and can not create dangerous light reflections.

2.7 VIBRATIONS

In standard conditions conformed to the indication of machine proper utilization the vibrations do not create dangerous conditions. The average quadratic weighed level, according to the acceleration frequency to which arms are exposed does not exceed 2,5 m/s².

2.8 NOISE EMISSIONS

The machine is designed and projected for reducing the noise emission level to its source. In standard working conditions the Machine noise power level is:

Acoustic Continuous Equivalent weighed pression A	<70dB
Acoustic Istantaneous weighed pression	<130dB

The noise levels indicated are emission levels and are not representative of operating levels. In spite of an existing relationship between emission levels and exposure ones, this can not be used in a reliable way to define if further precautions are necessary. The factors determining the exposure level to which the working force is subjected, include exposure length, working premises characteristics and other noise sources (number of machines, closed building, etc...). Furthermore the allowed exposure levels could change according to several Countries. At any rate, the information provided will allow the Machine Operator to achieve a better evaluation of the danger and risks they are submitted to.



The indicated noise levels are emission ones measured in standard conditions of use. In case of any machine modification, the above mentioned levels could be changed and should be tested on the same machine.

2.9 TECHNICAL DATA

We have listed below the Machine's data and technical characteristics to which you can make reference for any eventual contact with your distributor for Technical Assistance.

TABLE 2.9 A Technical data

- Frames thickness	min-max	.24"- 3.15"
- Frames width	min-max	.24"- 3.15"
- V-nails magazine capacity		n. 230
- V-nails size		7, 10, 15 mm.
- V-nails size on request		3,5, 12 mm.
- Pneumatic Supplying		40-100 PSI
- Weight		about 71 LB
- Height of working bench		4.3"
- Overall dimensions		18.9"x 11.8"x 11.8"

2.10 STANDARD EQUIPMENT

The equipment listed below is standard.

2.10.1 Standard accessories

Once you have removed the packaging, please check the presence of the following accessories:).

- N.1 nail head mm. 7
- N.1 nail head mm.10
- N.1 nail head mm.15
- N.1 L shaped pressure pad
- N.1 Rounding pressure pad
- N.1 Allen Wrench 5 mm. for V-nails head replacement
- N.1 Brass rod magnet to remove V-nails

2.10.2 Upgrading and implementing of mechanical parts

The machine has been realized following a modular criterion, therefore the existing equipment can be further upgraded with additional accessories that will not alter its basic structure. Technical upgrades on the machine model, if any, will be such that they can be installed at any time without requiring any substantial modifications to the machine's structure.

2.10.3 Optional accessories

- Floor stand
- Adjustable tilting fences (see fig. 3)
- Wooden support table
- Metal support extensions (fig. 1A)
- Special fences for octagons (fig.2)
- Special fences for hexagons (fig.1)
- Round and square pressure pads in rubber
- V-nails claw heads size 3-5-12 mm.
- Double mechanical pressure pad
- Triple mechanical pressure pad

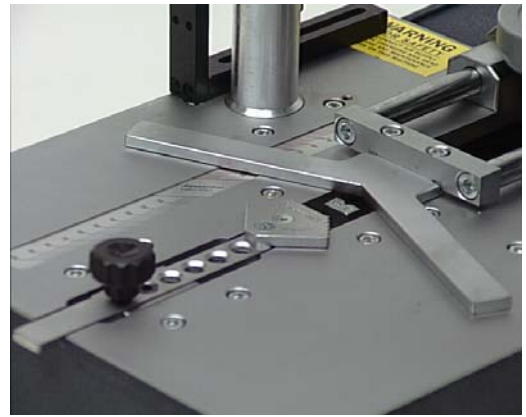

Picture 1



Picture 2



Picture 3

2.10.4 Customized optional accessories

Thanks to its versatility this machine can be ‘custom-made’ to meet our users requirements, with additional accessories that can make the frame assembling easier: e.g. special fences for peculiar moulding shapes, special clamps to ensure the mouldings are locked properly during V-nail firing, and so on. These can be made at your local machine shop.

2.11 ELECTROMAGNETIC AMBIENT

The Machine is designed to operate properly in an industrial electromagnetic ambient without altering it being an exclusively pneumatic machine.

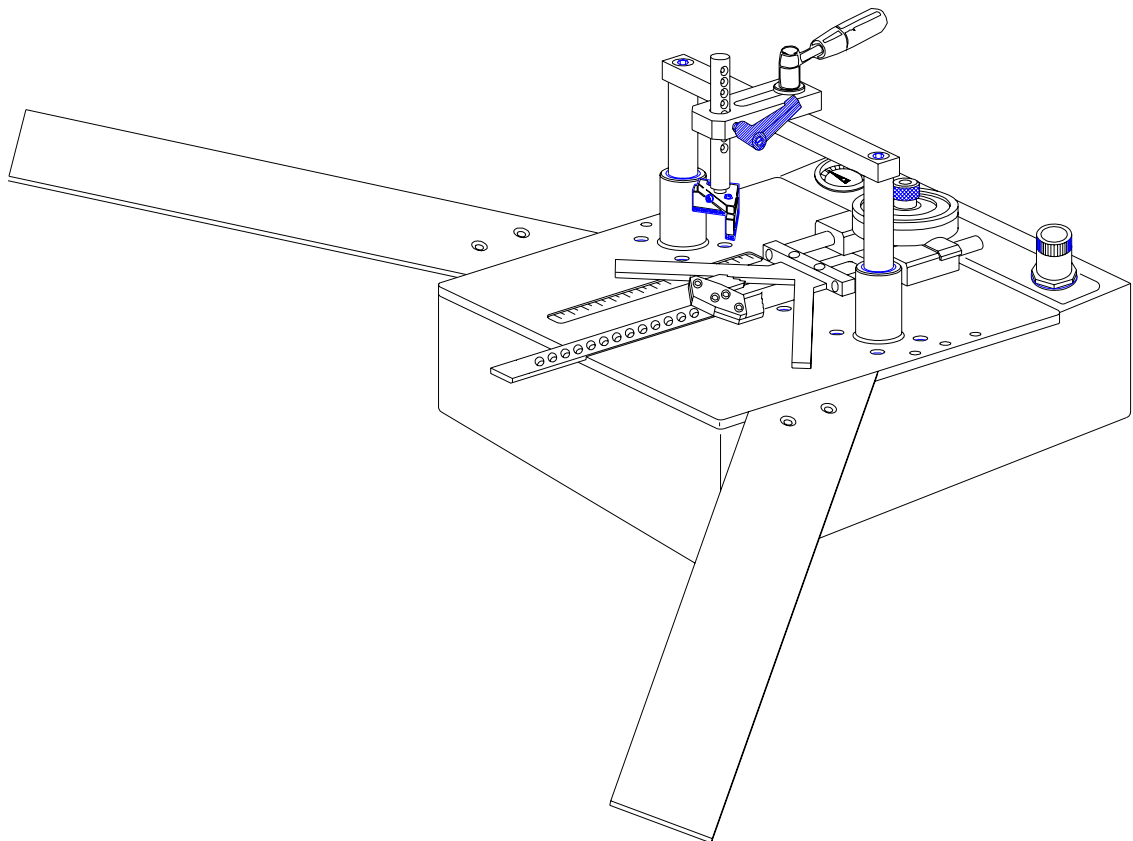

Figure 1A

3. SAFETY

3.1 GENERAL WARNINGS

The operator must pay the maximum attention to the information written in this Handbook, expressly about the proper precautions for Safety listed in this chapter.

It is indispensable for the operator to follow the warnings listed below:

- Keep the machine & the working area clean & ordered
- Provide appropriate containers to stock the pieces you will be working with.
- Use the Machine only in a normal psycho physical condition
- Wear adequate clothing to avoid obstacles and/or dangerous entanglements to/from the machine
- Wear the individual protection gears prescribed by the instruction handbook, regarding the effected operations
- Do not remove or alter the warning plates and adhesive signs
- Do not remove or elude the Machine Safety Systems
- Keep the fingers away from the working area
- Disconnect the air pressure supply during any maintenance intervention
- Keep your foot off of the pedal during Machine maintenance

3.2 SCHEDULED USE

The Machine is designed and built to execute junctions of frames.

The machine is projected for manual use only (under operator control).

3.3 INADVISABLE USE

The machine can not to be used:

- For uses different from those listed in 3.2 paragraph
- In an explosive or aggressive atmosphere where there is a high density of dust or oily substances suspended in the air
- In a flammable atmosphere
- Outside in all weather severity
- For working materials not suitable with the machine's characteristics

3.4 DANGEROUS AREAS

The area where the frames are assembled is defined as the "working area"

The dangerous areas of machine, include the movable parts and surrounding zones

Figure 3.4.A- Working area and dangerous zones

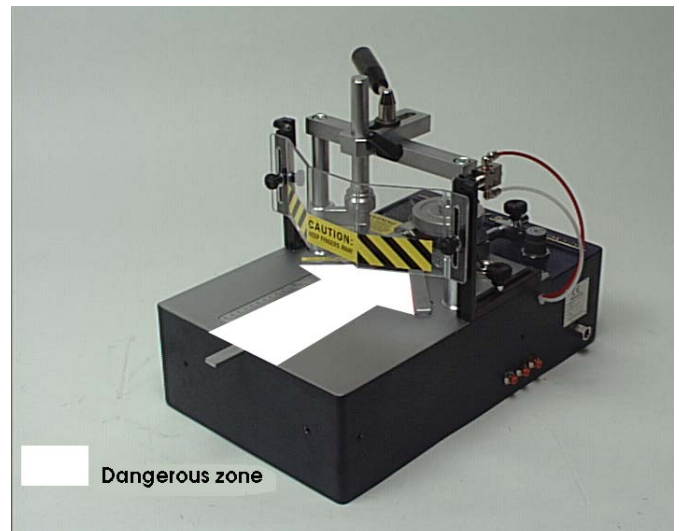

3.5 PROTECTION DEVICES

The machine is equipped with adequate protections for persons exposed to the risks due to the transmission of mobile elements taking part in working (driver blade, horizontal clamp, vertical clamp).

3.6 STOP FUNCTIONS

The machine stop functions are the following:

- Fast clutch fitting stop (Category 0).
- Foot pedal Stop (Category 1).

STOP CATEGORY 0

It is obtained by disconnecting the fast clutch fitting from feeding system (uncontrolled stop).

STOP CATEGORY 1

Controlled stop obtained by lifting the foot from the pneumatic pedal that does not allow the v-nails to drive.

3.7 SAFE WORKING PROCEDURES



The machine is projected and realized to eliminate any risk connected with its use. The user is requested to achieve an adequate training to be instructed by your local distributor or ITW/AMP's technicians.

The other risks related with using the machine are:

- Finger crushing in the frontal clamp working area

It is necessary to carefully follow the following instructions:

- 1 Keep the fingers away from frontal and vertical clamp working areas
- 2 Disconnect the air pressure and during any maintenance interventions
- 3 Keep the foot away from the pedal during machine maintenance

3.8 RESIDUAL RISKS

During the normal working cycle and while performing maintenance the operators are exposed to several residual risks that because of the operations own nature can not be totally eliminated.

- Risk of finger crushing in the working areas of vertical and frontal clamping

3.9 PLATES

The warning plates carrying out safety functions can not be removed, covered or damaged.

To see the plates or adhesive signs location, consult the Fig.10.2-D

Table 3.8 A- Types of plates



Plate concerning machine characteristics



Adhesive sign concerning the finger danger zone



Adhesive sign concerning the behaviour to be kept during the working cycle



Adhesive sign concerning the behaviour to be kept during the working cycle

4. INSTALLATION

4.1 SHIPPING AND HANDLING

The shipment must be performed by a professionally qualified staff. The machine has to be shipped in a safe way to avoid any damage to its parts.

- All the protections and guard devices must be properly closed and locked.
- The machine has to be shipped like it is positioned for installation.
- Before the shipment it is necessary to lubricate the parts which are not painted.
- According to the type of shipment, it is necessary to protect the machine from any jarring impact or stress

Figure 4.1A – machine handling indications



Machine total weight: about 28 Kilos

	<p>Lifting the machine must be performed by 2 operators.</p>
--	--

Any damaging of the machine caused during its shipment or handling is not covered under warranty.

Repairs or replacements of damaged parts are charged to the customer.

4.2 STORAGE

In case of long inactivity, the machine must be stored with cautions concerning storage place and times.

- Store the machine indoors
- Protect the machine from jarring impacts and stresses
- Protect the machine from humidity and high temperatures
- Avoid corrosive materials that could touch the machine
- Lubricate the parts which are not painted

4.3 PRELIMINARY ARRANGEMENTS

In order to install the machine it is necessary to prepare a working area adequate to the machines dimensions & the length of moulding you will be working with.

To fulfill the characteristics of precision and steadiness, the bench frame assembling machines must be positioned on a solid and leveled plane able to sustain the weight of the machine. The bench must be studied and prepared by the customer and/or qualified staff.

4.4 UNPACKING

The benchtop machine is shipped & packed into an appropriate carton which is protected by polystyrene parts. Remove the external packing and save it for a future use.

Check for any casual shipping damage and report it immediately. Shipping damages or any other defects must be reported to *97001-ANCP* or your local distributor within 3 days from receipt of the machine.

4.5 CONNECTIONS

To avoid any problems while setting up the machine, it is suggested to follow the instructions listed below.

4.5.1 Pneumatic connection

The machine is controlled by a dual function foot pedal. The 3 pipes for the pedal must be inserted into the 3 fittings located on machine's right side in the following sequence

(fig. 4-5):

Upper connection	Red pipe into the red fitting (external side)
Ceter connection	Black pipe into the black fitting (center fitting)
Lower connection	Transparent pipe into the 3 rd fitting (user side)

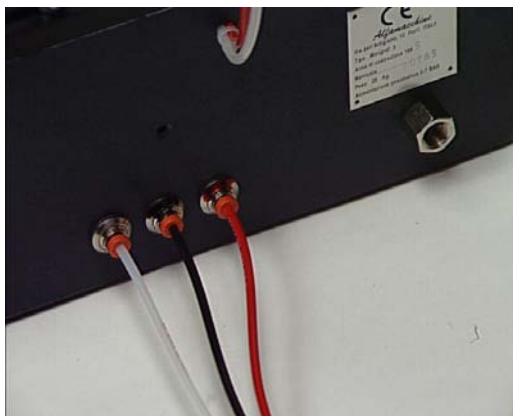

Picture 4

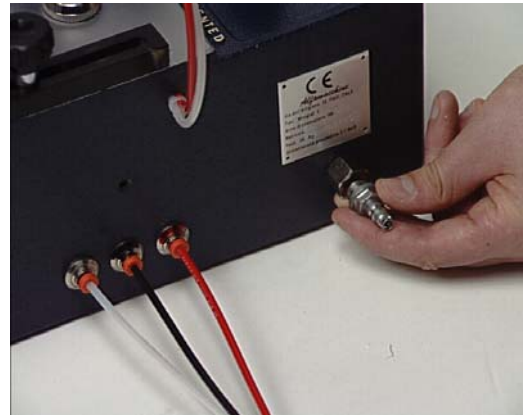

Picture 5

Use the supplied fast clutch fitting to connect to the air compressor system. You could use also another fitting suitable with your pneumatic system (see fig. 6).

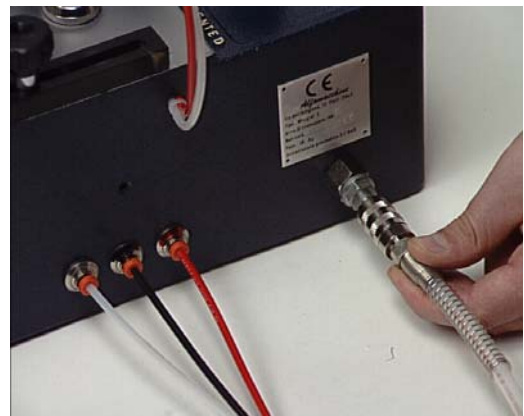

Picture 6



It is advisable to install a filter/lubricator on the air compressed system to obtain clean and lubricated air. Use only silicone lubricating oil for pneumatic systems. The use of inadequate oil could damage the valves.

Once you have connected the machine with the pneumatic system, check the operation of the foot pedal in the following way:

- Pressing the foot pedal half way down activates the horizontal clamp, vertical clamp and the fence locking
- The foot pedal pressed full down activates the V-nail



Check the foot pedal operation when the V-nail magazine is closed. The foot pedal control is deactivated when the V-nail magazine is opened.

4.6 PRELIMINARY CONTROLS

The preliminary operations before starting the machine, must be executed by a technician appointed by the customer. Before setting up the machine, it is necessary to execute certain verifications and checks to prevent mistakes or accidents during setup.

- Verify that machine has not been damaged during the assembly steps.
- Verify with extreme care, the pipes integrity

4.7 MACHINE ARRANGEMENT

4.7.1 V-Nails magazine loading

To load the V-nail magazine proceed as follows:

- Move the claw pusher backwards by flipping the special lever located on the right side of the machine working bench. This will give you access to the V-nail magazine (see fig. 7).
- Insert one or more V-nail strips into the magazine. Make sure that the sharpened edge of the V-nails (glue side) faces up and that they are loaded with the V of the V-nails pointing in the direction indicated in the figures 8 and 9. Check to see if the V-nail size is suitable with the type of claw head mounted.
- Move the claw pusher forward by flipping the control lever (see fig.7)

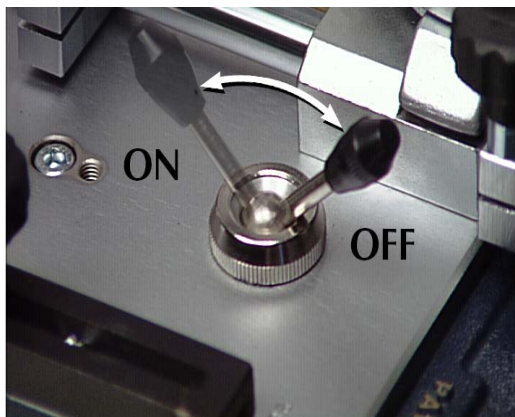

Picture 7



Picture 8

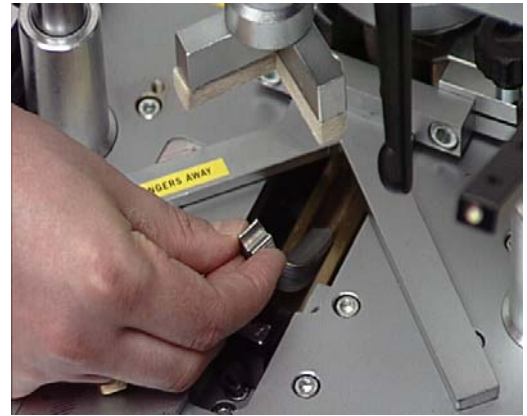

Picture 9

4.7.2 V-nail guide head replacement to change V-nails size

The V-nail guide head must be changed each time you use V-nails of different sizes.

Proceed as follows to replace it:

- Loosen the locking screw of the V-nail guide head using the proper 5 mm Allen wrench (the screw is on the opposite side from the V-nails magazine(See fig. 10)
- Take out the V-nail guide head
- Move the clawpusher backwards by flipping the special lever located on the right side of the machine working bench. (see fig. 8).
- Remove all the V-nails that are still in the magazine (using the proper brass magnet, if necessary).
- Insert the new V-nail strip (of desired height) into the magazine
- Move the clawpusher forward by flipping the control lever (see figure 7).
- Insert the new size V-nail guide head to match the V-nails you will be using (see fig. 11).
- Tighten the locking screw of the V-nail guide head (see fig.10).



picture 10



picture 11

4.8 ADJUSTMENTS

The machine has been completely tested and checked in ITW/AMP's plants before its shipment. All the operator has to do is perform the following adjustments:

4.8.1 V-nails inserting positions adjustment

To properly position the mouldings to be assembled, the Mitre-Mite VN 2+1 is equipped with a 90° fence.

The fence can be shifted forward or backward in order to allow the proper positioning of the v-nails in the moulding. The fence stops (backward and forward) can be set with precision by means of locking clamps (see fig. 13).

The operator can easily use the machine to insert V-nails with extreme precision into 2 different positions (fig. 14).



picture 13



picture 14

4.8.2 Vertical clamp adjustment

The vertical clamp can be adjusted in height and position. Proceed as follows to adjust them:

4.8.2a Vertical clamp position adjustment

- Position the mouldings to be assembled on the working bench
- Select the pressure pad suitable with the profile of the moulding to be assembled and put it on the vertical bar
- Loosen the handle (see fig.15) that locks the clamp, which holds the vertical bar. This will permit its movement forward or backward. You want the pressure pad directly over the V-nail insertion point.
- Tighten the handle once you have reached the proper position

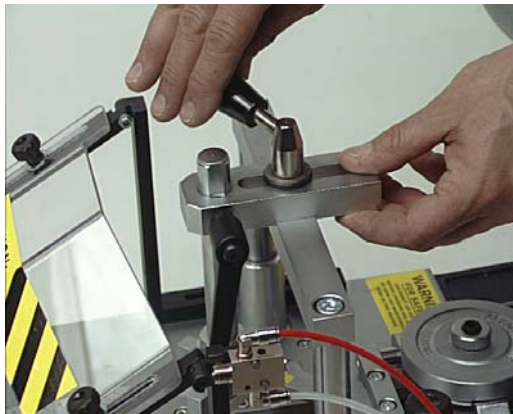

Picture 15

4.8.2b Vertical clamp height adjustment

- Loosen the side (see fig. 16) handle and adjust the pressure pad height over the frame. It is suggested that you put the bar height between 3/16" - 1/4" over the moulding. This will help avoid any accidental fingers crushing.
- Tighten the handles once you have reached the proper position
- Lower the vertical clamp by pressing half way down on the foot pedal. This will verify that the mouldings to be assembled are properly clamped
- Press all the way down on the foot pedal to insert the V-nail.

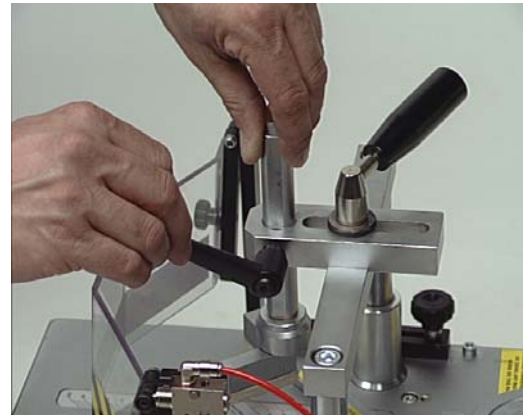

Picture 16

4.8.3 Frontal clamp adjustment

The Frontal Clamp (horizontal clamp) has a series of holes in the flat bar (see fig.17).

Lift the bar, to take it out of its initial position. You will now be able to move it forward and backward.

To lock the bar it is sufficient to insert it into the proper peg located in the middle of the guide channel.

Proceed as follows to position the frontal Clamp correctly:

1. Remove the bar off of the peg by lifting it by about 3/8" - 5/8". Move it forward until it touches the moulding to be assembled (see fig.18);
2. Lower the bar into the next available hole and over the peg.

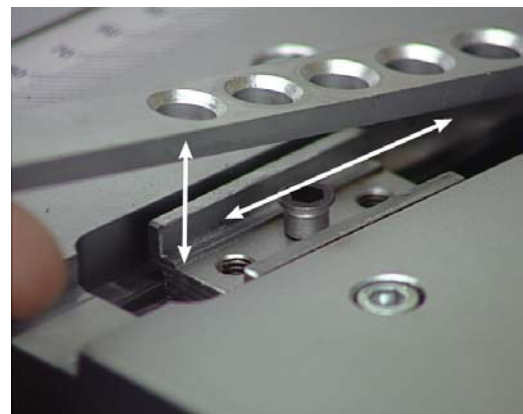

Picture 17

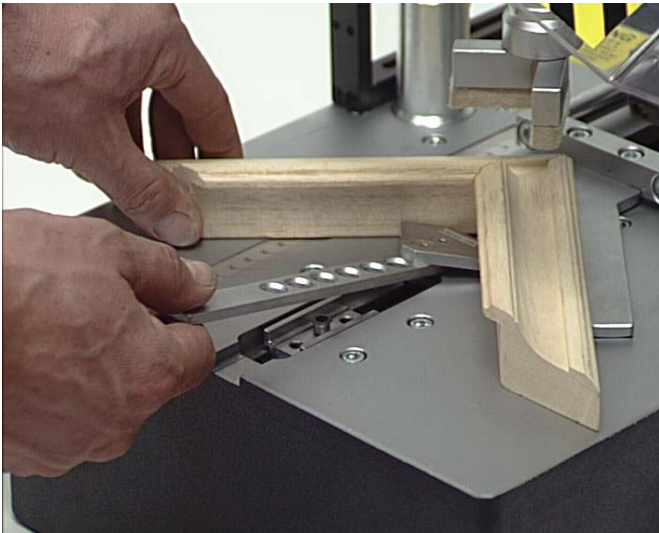

Picture 18

	<p>In case of continued use without needing to remove the frontal clamp from its position, it is possible to fix it into the peg using the proper screw. When shipping the machine it is advisable to lock down the frontal clamp by using the supplied knob.</p>
---	---

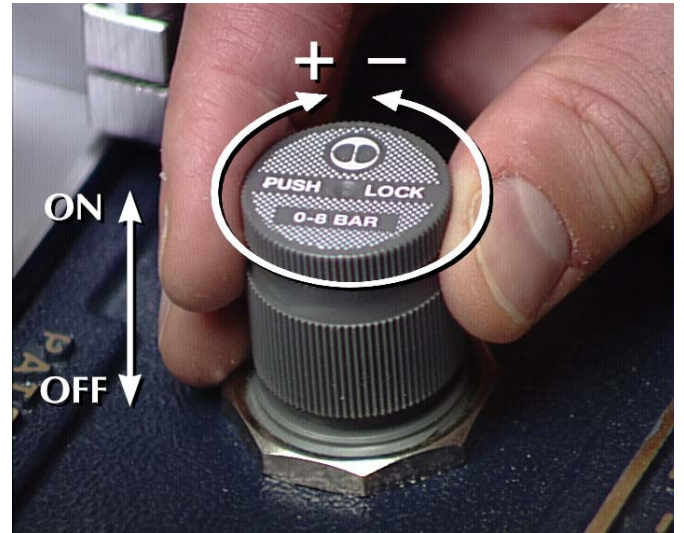

Picture 19

	<p>DO NOT ADJUST the pressure if the machine is not connected to the air supply.</p>
---	---

The suggested pressures are:

Soft woods	(samba,.....)	30 - 40 PSI
Medium	(ramin,.....)	40 - 60 PSI
Very hard woods	(oak)	60 - 80 PSI

The above listed values apply to 7 and 10 mm high V-nails. Increase the pressure by 10 % for 15 mm high V-nails. When stacking 2 or more V-nails, increase the working pressure by 10 to 15 %.

4.8.4 Working pressure adjustment

The working pressure must be adjusted to the hardness of the mouldings to be assembled.

The pressure regulation allows you to change the clamping pressure of mouldings to be assembled.

Too high of a working pressure can cause a poor junction and (especially on small-size frames) the moulding could be crushed.

Too low of a working pressure can cause an incomplete insertion of the V-nail into the frame.

The working pressure is adjusted by means of the regulator on the panel near the pressure gauge (see fig. 19).

Proceed as follows to adjust the working pressure:

1. Pull up the regulator cap by about 1/8". This will unlock it.
2. Turn it clockwise to increase the pressure and counter-clockwise to decrease it.
3. Push the regulator cap back down to lock it into position

4.8.5 Protective shield adjustment

You can order a protective shield made of transparent plastic material. (see fig. 20).



picture 20

Proceed as follows to adjust the protection shield:

1. Loosen the 2 knobs which hold the shield in place and lift or lower it to a height of about 1/4" - 3/8" from the top of the moulding.
2. Tighten the knobs to lock the protection shield.

Even if the protective shield is properly adjusted, it is necessary following instructions listed below:

- 3 Keep the fingers away from the frontal and vertical clamp working area.
- 4 Disconnect the pressure supply during any maintenance intervention.
- 5 Keep your foot off of the pedal while adjusting the machine.

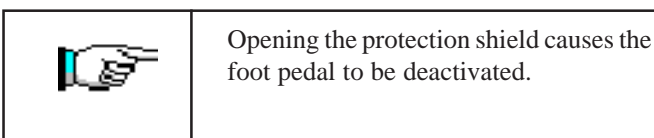

4.9 CHECKING OPERATIONS TO BE EFFECTED BEFORE WORKING START

Once the machine has been properly installed (like previously described), check that:

- The mouldings to be assembled are properly positioned on the working bench
- The magazine is loaded with the type of V-nails suitable with the mouldings to be assembled
- The adjustment of the vertical and horizontal clamps are correct (chapter 4.8.2 and 4.8.3)
- The working pressure is adequate to the wood hardness (see chapter 4.8.4)
- Pressing halfway down on the pedal both the frontal and vertical clamps hold the frame properly
- The protective shield is properly positioned (see chapter 4.8.5)

Press the pedal all the way down to insert the V-nail

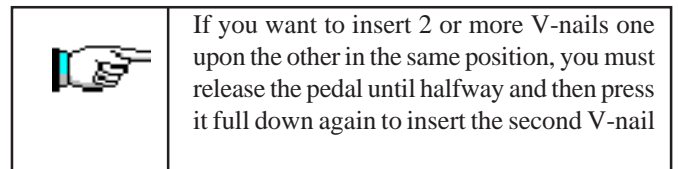

5. FUNCTIONING

5.1 OPERATORS

The machine has been projected to be used by only one operator.

The staff assigned to operate the machine, must be in possession (or acquire through an adequate training) the requirements indicated below. In addition they must have the knowledge of this handbook and every information concerning safety:

- General and technical culture sufficient to comprehend the handbook contents and properly understand the drawings and schemes
- Knowledge of the main sanitary, technological and anti-accidental norms
- Overall knowledge of the production line and plant where the machine is installed
- Specific experience in the assembly of frames
- To know how to operate in case of emergency, where to find the individual protection means and how to use them properly.

The Maintenance people in addition to the above mentioned characteristics must be in possession of an adequate technical education.

5.2 FUNCTIONING DESCRIPTION

The machine has only one possible operating mode:

- Manual functions by using the pneumatic foot pedal.

Press the foot pedal half way down to clamp the frames

Press the foot pedal all the way down to drive a v-nail.

To assemble a frame junction, you must operate as follows:

- 1 Set the inserting positions by means of the fence locking clamps
- 2 Place the moulding on the working bench. Move the fence to the first inserting point.
- 3 Adjust the vertical clamp height and position
- 4 Adjust the frontal clamp position
- 5 Verify and adjust the proper working pressure according to the mouldings to be assembled.
- 6 Press half way down on the pneumatic pedal to verify the proper position and clamping of the moulding.
- 7 Press the pedal all the way down to insert the V-nail. If you want to insert 2 or more V-nails, one upon the other in the same position, you must release the pedal halfway and then press it all the way down again to insert the second V-nail and so on.
- 8 Completely release the foot pedal
- 9 Move the moulding and the fence to the next inserting point and repeat the steps 6,7 and 8.

5.3 TIPS FOR PERFECT JUNCTIONS

a) V-nail types

In order to allow the machine to make excellent quality joints using different materials, it has been necessary to manufacture different V-nails types for different uses (see attachment D).

V-nails can be classified in three different groups:

for soft woods and soft plastic	Suggested V-nails code	SPT
for medium woods	Suggested V-nails code	HPT
for hard woods	Suggested V-nails code	HPT

b) Assembling positions

It is advisable to operate as follows in order to achieve the best results in terms of junction quality:

Never drive V-nails near the junction vertex. The minimum recommended distance from the external vertex is at least 10 mm.

When you want to make the junction using only one V-nail, the most suitable position is in the middle of the moulding (see fig. 21)

In case you want to insert 2 or more V-nails into each junction, we recommend you to insert the most external one 1/3 from the external vertex and the most internal one 1/4 from the internal vertex.

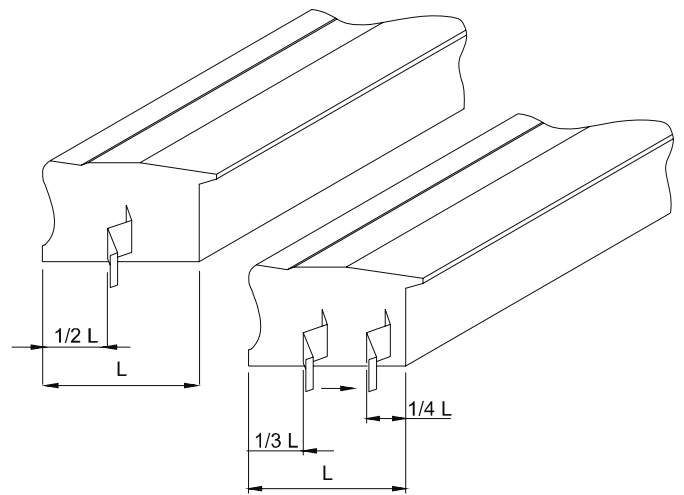

picture 21

5.4 MACHINE STOP

The machine can only work by pressing the pneumatic foot pedal. To stop it, lift your foot from the pedal.

It is possible also to disconnect the fast clutch fitting from the compressed air.

5.5 MACHINE REINSTATEMENT

The machine reinstatement is performed by pressing the pneumatic foot pedal.

5.6 PUTTING OUT OF SERVICE

In case on long inactivity periods it is necessary to disconnect the fast clutch fitting from pneumatic system.

6. MAINTENANCE

6.1 STATE OF MAINTENANCE

The maintenance operations must be performed with the machine in the conditions described at “state of the machine” in the tables 6.6.A and 6.7.A

6.2 MACHINE ISOLATION

Before performing any type of maintenance or repair it is necessary to isolate the machine from it’s supply sources by performing these operations:

- 1) Disconnect the fast clutch fitting from the pneumatic system.

Once you have completed the maintenance & before reactivating the pneumatic supply, make sure that any component and any pneumatic connections are properly reinstalled.

6.3 SPECIAL CAUTIONS

During the maintenance or repair operations is suggested to proceed as follows:

- Before starting any operation place a sign “machine under maintenance” in a well visible position.
- Do not use solvents or flammable materials
- Do not step on the machine parts, because they have not been projected to sustain the weight of persons.
- Put on a pair of safety glasses.
- Once all the operations are finished replace any protections and shields you removed or opened.

6.4 CLEANING

The machine structure is simple and robust therefore the mechanical parts do not require any special maintenance.

It is advisable to follow the rules listed below:

- Regularly remove glue or other residues from the V-nail head and from the upper part of the driver blade;
- Always keep the v-nail magazine clean and without residues.
- Remove any residues from the V-nails guide “L” shaped support.

Do not use water to clean the machine, otherwise metallic parts may rust.



Before performing any cleaning intervention, the operator must disconnect the pneumatic system..

6.5 LUBRICATION

Use preferably CASTROL MAGNA GC 32 or equivalent oil

Furthermore, we recommend to lubricate the driver blade every 200 working hours.

	<p>Unsuitable lubricants may cause valve seal problems (seals may become too large) and consequent Valve jamming.</p>
---	---

6.6 ORDINARY MAINTENANCE

The following operations must be performed at the times indicated below. Not observing the following instructions exonerate the Producer from any responsibility regarding the warranty.

The operations described here below, even if simple, must be executed by qualified personnel.

The scheduled ordinary maintenance includes overhauls, checks and interventions that, to prevent stops and breakdowns, keep the system working properly:

- Lubrication state of the machine
- Wear and tear parts state

TAB 6.6 A

Maintenance	Description	Machine state
V-nail driver blade	Replacement every 1.000.000 V-nails shot	Isolation for maintenance
Movable parts lubrication	Lubricate the driver blade every 200 working hours	Isolation for maintenance
V-nails claw heads	Replacement every 5.000.000 V-nails shot	Isolation for maintenance
“L” shaped supports (V-nails guide)	Replacement every 5.000.000 V-nails shot	Isolation for maintenance

6.7 EXTRAORDINARY MAINTENANCE

Listed below are the operations that need the intervention of ITW/Amp or your local distributor’s Technical Assistance (see the paragraph 1.2). You can also use qualified staff authorized by the Producer

The extraordinary maintenance includes interventions to be performed in exceptional cases:

- Breakage
- Revisions

TAB. 6.7 A

MAINTENANCE	DESCRIPTION	MACHINE STATE
Valves and Reducers	Suggested replacement every 6/8 million of V-nails shot	Isolation for maintenance
Frontal and vertical clamping gaskets	Replacement in case of leak of air	Isolation for maintenance

7. DIAGNOSTIC

7.1 SAFETY WARNINGS

The interventions must be executed by personnel properly trained and they must take all precautions in order to avoid accidental starts.

7.2 TROUBLESHOOTING

TABLE 7.2 - A

TROUBLE	POSSIBLE CAUSE	REMEDY
Pressing the foot pedal the V-nails ejection is irregular	Insufficient working pressure	Check that the minimum value indicated from main regulator is higher than 3 Bar
Pressing the foot pedal the V-nails ejection is irregular	V-nails wrongly positioned into the magazine	<ul style="list-style-type: none"> - Check that the V-nails sharpened side (glue side) faces up - Check that V-nails V vertex is pointing toward machine's external side
Pressing the foot pedal the V-nails ejection is irregular	Guide channels damaged or jammed	- Check that the guide channels are not dirty or jammed
Pressing the foot pedal the V-nails ejection is irregular	Claw pusher has insufficient thrust	Check that the pressure of the regulator feeding the claw pusher cylinder is at least 2 Bar. If necessary, increase it by 10%.
Pressing the foot pedal the V-nails ejection is irregular	Claw head not suitable with V-nails size	Check that the number engraved on the v-nail claw head match the V-nails size
Pressing the foot pedal the V-nails ejection is irregular	Faulty V-nails	- Replace the V-nails
Pressing the foot pedal the V-nails ejection is irregular	Insufficient working pressure	Check that the air pressure coming out from the compressor is at least 3 Bars.
Pressing the foot pedal the V-nails ejection is irregular	Opened V-nails magazine	Close the magazine by means of the special lever
Pressing the foot pedal the V-nails ejection is irregular	Faulty valves	<ul style="list-style-type: none"> - Replace the foot pedal valve - Replace the control valves
Pressing the foot pedal for several times the machine's working that was correct at the beginning becomes irregular later	Jammed valves because of surplus of oil or condensation	-Remove the surplus of oil and condensation from the valves by disconnecting the air lines one by one . This will force out the oil/water.
Pressing the foot pedal the working pressure indicated on the regulator deeply decreases	Faulty pressure regulator	-Replace the regulator
Pressing the foot pedal the working pressure indicated on the regulator deeply decreases	Air supply line too long or of inadequate diameter	Replace their line with a new one of bigger diameter

TROUBLE	POSSIBLE CAUSE	REMEDY
Pressing the foot pedal the machine works properly, but once the pedal is released you can note a certain delay in the re-positioning of the driver blade and/or vertical clamp cylinders	Faulty or jammed valves	<ul style="list-style-type: none"> - Remove the surplus of oil and/or condensation - Replace the foot pedal valve - Replace the faulty control valves
Wishing to insert several V-nails one upon the other in the same point, they do not stack properly or tilt during their insertion	Unsuitable V-nails	Replace the V-nails with suitable ones
Wishing to insert several V-nails one upon the other in the same point, they do not stack properly or tilt during their insertion	Poor frames clamping (the frame moves during the V-nail insertion)	<ul style="list-style-type: none"> - Check and reposition the vertical and frontal clamps - Increase the pressure by using the regulator - Replace the pressure pad with the proper one
Wishing to insert several V-nails one upon the other in the same point, they do not stack properly or tilt during their insertion	Wore and torn driver blade	Replace the driver blade
Wishing to insert several V-nails one upon the other in the same point, they do not stack properly or tilt during their insertion	Jammed driver blade	Clean the driver blade's upper part by removing any material jamming the upper profile

7.3 REQUEST OF ASSISTANCE

For any information regarding Use, Maintenance, Installation, etc.. we remain at your disposal. The Customer has to formulate clearly their questions by sending us fax listing detailed descriptions of the troubles met. For eventual explanations you should use this handbook and to the instructions listed in the paragraph 1.2 for reference.

FAX: 1-800-426-7019
Phone: 1-800-322-4204
E-Mail: itwamp@paslode.com
Web Site: www.itwamp.com

8. SPARE PARTS

8.1 SPARE PARTS LIST

Even though the machine has been submitted to several tests and functional checks, we listed below the components that we suggest you to have a minimum and sufficient set of. This will help guarantee the shortest possible downtime.

TABLE 8.1 - A

COMPONENT
<ul style="list-style-type: none">• V-NAILS DRIVER BLADE• V-NAILS CLAW HEADS “L”• SHAPED SUPPORT (V-NAILS GUIDE)• VALVES-REDUCERS-REGULATORS• VERTICAL AND HORIZONTAL CLAMPING GASKETS

8.2 SPARE PARTS ORDERING

We remind you that only a qualified technician can repair the machine.

Therefore we suggest the intervention of your local distributor or ITW/AMP's Center of Technical Assistance, which has access to qualified staff, proper equipment and tools, and who uses original spare parts.

To order the above spare parts, send the following data by fax or letter:

- Model of the Machine
- Code of exploded drawing
- Reference number of spare part or group indicated on the mechanical drawing
- Code number of single or group spare part

9 DEMOLITION

9.1 DEMOLITION

At the act of demolition it is necessary to separate the parts in plastic material from electric components. Sometimes they must be sent to different gatherings respecting the current Norms.

Concerning the machine metallic mass, it is enough to subdivide the steel parts and those of other metals or alloys, for a proper recycling by smelting.

10. ATTACHMENTS

10.1 DECLARATIONS

You can find here attached the following declarations

- Declaration of conformity to the Norm 89/392/CEE

10.2 SCHEMES

You can find here attached the following schemes:

- (A) Mechanic Schemes
- (B) Pneumatic Scheme
- (C) Plates Dislocation
- (D) Sharpening Table

MITRE-MITE VN2+1

Disegno DWG Nr. 021.0.100

Rev.1 / 01 - 1997

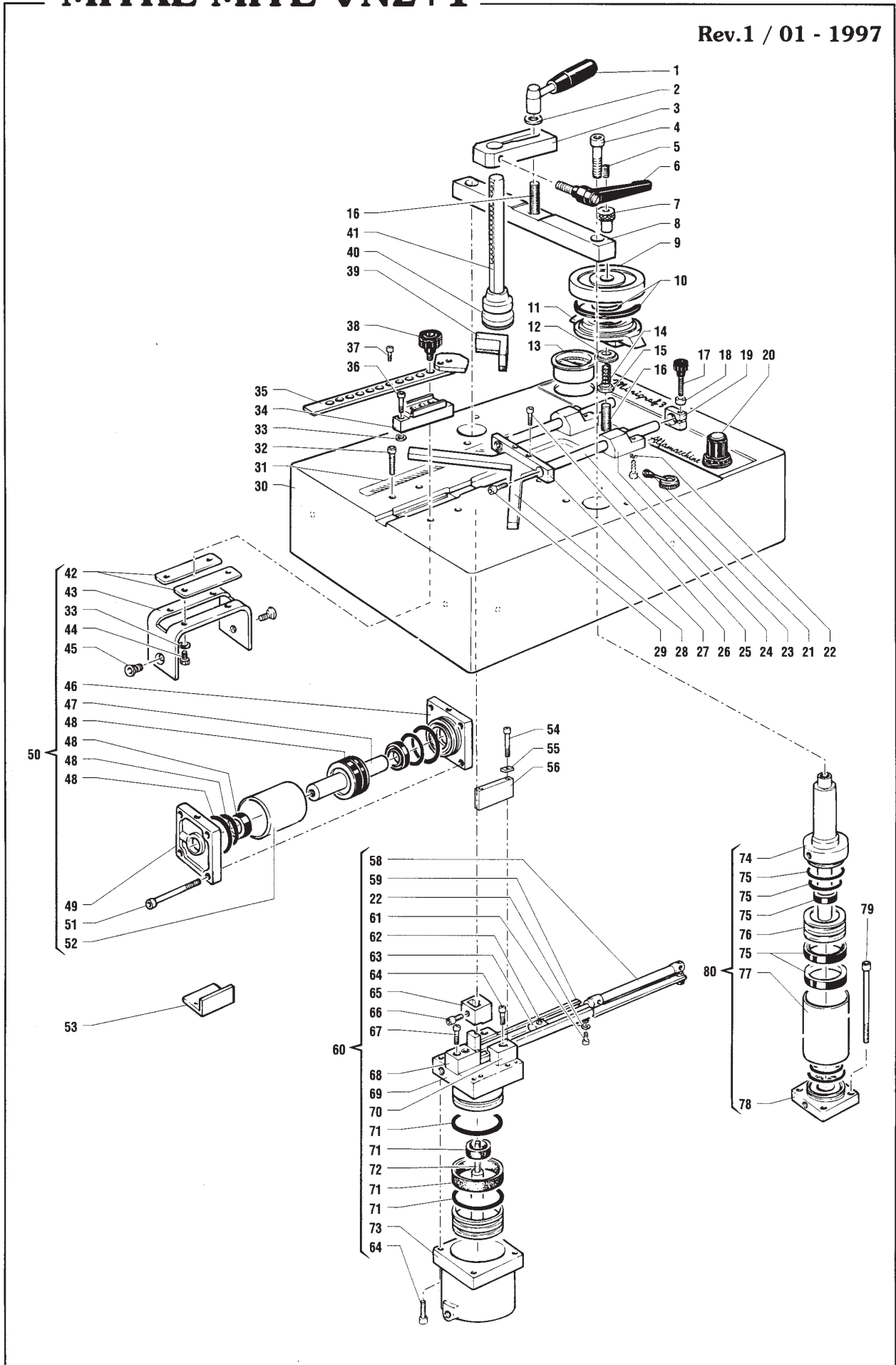

MITRE-MITE VN2+1

DWG Nr. 021.0.100

Optional

Rev.1 / 01 - 1997

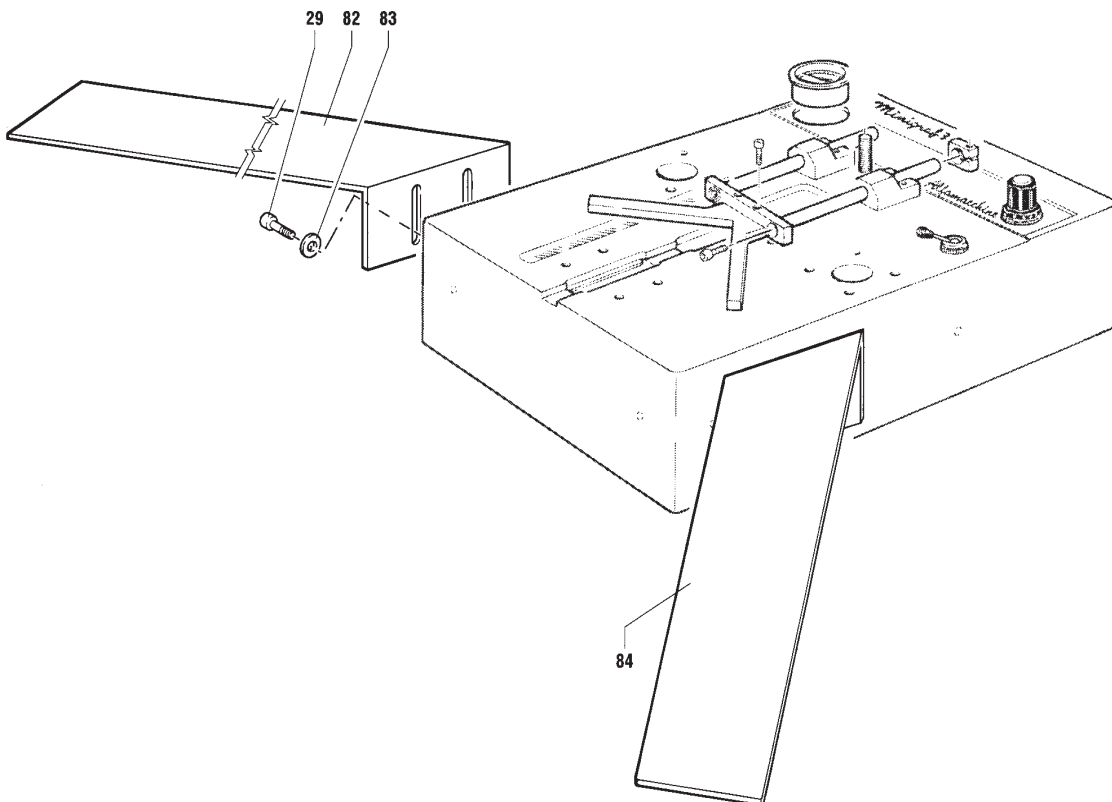
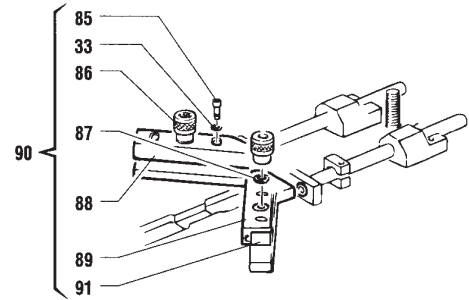
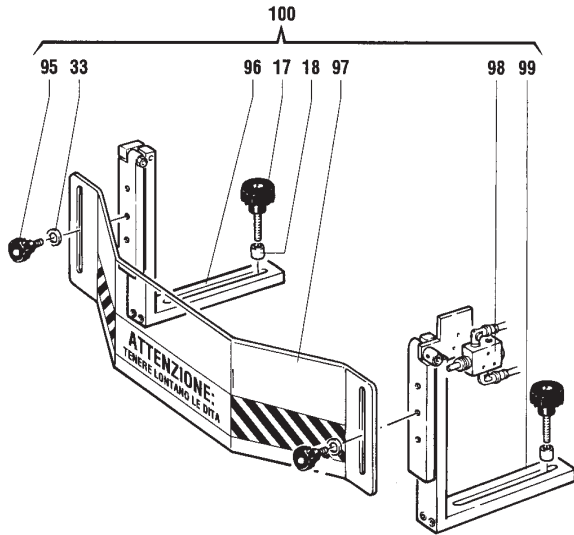

Mitre Mite® VN 2+1

Dwg nr. 021.0.100

Ref.	Item	Qty	Description
1	244660010	1	Ratchet Handle For Top Slide 12mm x 1.25
2	336100030	1	Washer OD=30 ID=12
3	383600061	1	5" Hold Down Rod Clamp 14mm
4	710100151	2	Screw
5	714300042	1	Screw
6	243170010	1	Ratchet Handle For Hold Down
7	336300010	1	Knob
8	376400010	1	Support
9	225170010	1	Complete brake
10	298390060	1	Gasket Kit AFC + Brake Cylinder OD=93 ID=38
12	336100040	1	Washer
13	734230008	1	Pressure Gauge Main
14	765000004	1	Spring
15	336100050	1	Washer
16	714300041	2	Set Screw 12 x 60 1.25 Pitch
17	753320002	2	Fence Stop Clamp Knob
18	336100020	2	Washer For Fence Stop Clamp
19	393150010	2	Fence Stop Clamp
20	735630002	1	Pressure Regulator 1/8" 0-8 Bar
21	732140001	1	Pneumatic Loading Valve (PLV)
22	718100002	6	Washer
23	710100045	4	Screw
24	383900010	2	Support
25	334000020	2	Slide
26	710100072	4	Screw
27	383900020	1	Support
28	375200010	1	Fence 90 Degree
29	710100112	2	Screw
30	211250040	1	Main frame
31	366710080	1	Inch rule
32	710100076	4	Screw
33	718100003	10	Washer
34	392750011	1	Support
35	242170010	1	Front Clamp
36	710100074	2	Screw
37	366210030	1	Screw
38	753320001	1	Front Clamp Knob
39	242230020	1	Square pressure plate with felt for magnetic base
39	242230140	1	Square pressure plate with rubber for magnetic base
40	242230010	1	Round pressure plate with felt for magnetic base
40	242230040	1	Round pressure plate with rubber for magnetic base
40	242230060	1	Square Pressure Plate with Rubber bolt on part
41	244120120	1	Magnetic Rod Complete
41	244120130	1	Base For Magnetic Hold Down Rod
41	334000181	1	Hold Down Rod D=20 L=160
42	371200010	2	Slide
43	384400010	1	Support
44	710600002	4	Screw
45	710200081	2	Screw
46	352200030	1	Head
47	331000030	1	Piston
48	298390050	1	Gasket Kit Front Clamp Cylinder OD=45 ID=22
49	352200020	1	Head
50	225120010	1	Complete Front Clamp Cylinder
51	710100087	4	Screw
52	333500020	1	Cylinder Sleeve
53	384200020	2	Bracket
54	710100086	4	Screw

Please Note: Parts in bold red text are available for purchase online at: www.itwamp.com

Mitre Mite® VN 2+1

Dwg nr. 021.0.100

55	381600100	4	Leveller Spacer
56	381300080	2	Spacer
58	221330010	1	Nail Feed Cylinder Complete
59	398350031	1	Steel Nail magazine 2000+
60	224240010	1	Complete Driver Cylinder
61	710100042	2	Screw
62	244500010	1	Set Screw + Pin (Clawpusher)
63	395450021	1	Clawpusher Post 2000
64	710100093	6	Screw
65	394950060	1	Nail Head H5
65	394950020	1	Nail Head H7
65	394950030	1	Nail Head H10
65	394950040	1	Nail Head H12
65	394950050	1	Nail Head H15
66	710100070	5	Screw scs 6 X 8
67	710100079	2	Screw
68	384200050	1	L-Support Block
69	352200060	1	Head
70	383600020	2	Block For Magazine
71	298390041	1	Gasket Kit Driver Cylinder VN
72	298420040	1	Piston & Driver Blade VN2+1
73	352200050	1	Cylinder
74	352400020	2	Head For Vertical Cylinder
75	298390070	2	Gasket Kit Vertical Cylinder
76	331000020	2	Piston
77	333500030	2	Cylinder Sleeve
78	352200040	2	Bottom
79	710100088	8	Screw
80	225220010	2	Complete vertical Cylinder
82	391650511	1	Left Extension Arm
83	718100004	4	Special Washer
84	391650501	1	Right Extension Arm
84	291650010	1	Extension Arm Set
85	710100073	4	Screw
86	336300040	2	Knob
87	337500040	2	Special Washer
88	386200040	1	Left Fence Piece
89	386200030	1	Right Fence Piece
90	243160020	1	Tilt Fence Assembly Complete
91	381300140	2	Support
95	753320005	2	Knob D=20 M6x25
96	241300010	1	Support
97	398950020	1	Protective Shield
98	732540003	1	Valve For Safety Guard
99	241300020	1	Support
100	248950020	1	Safety Guard Complete

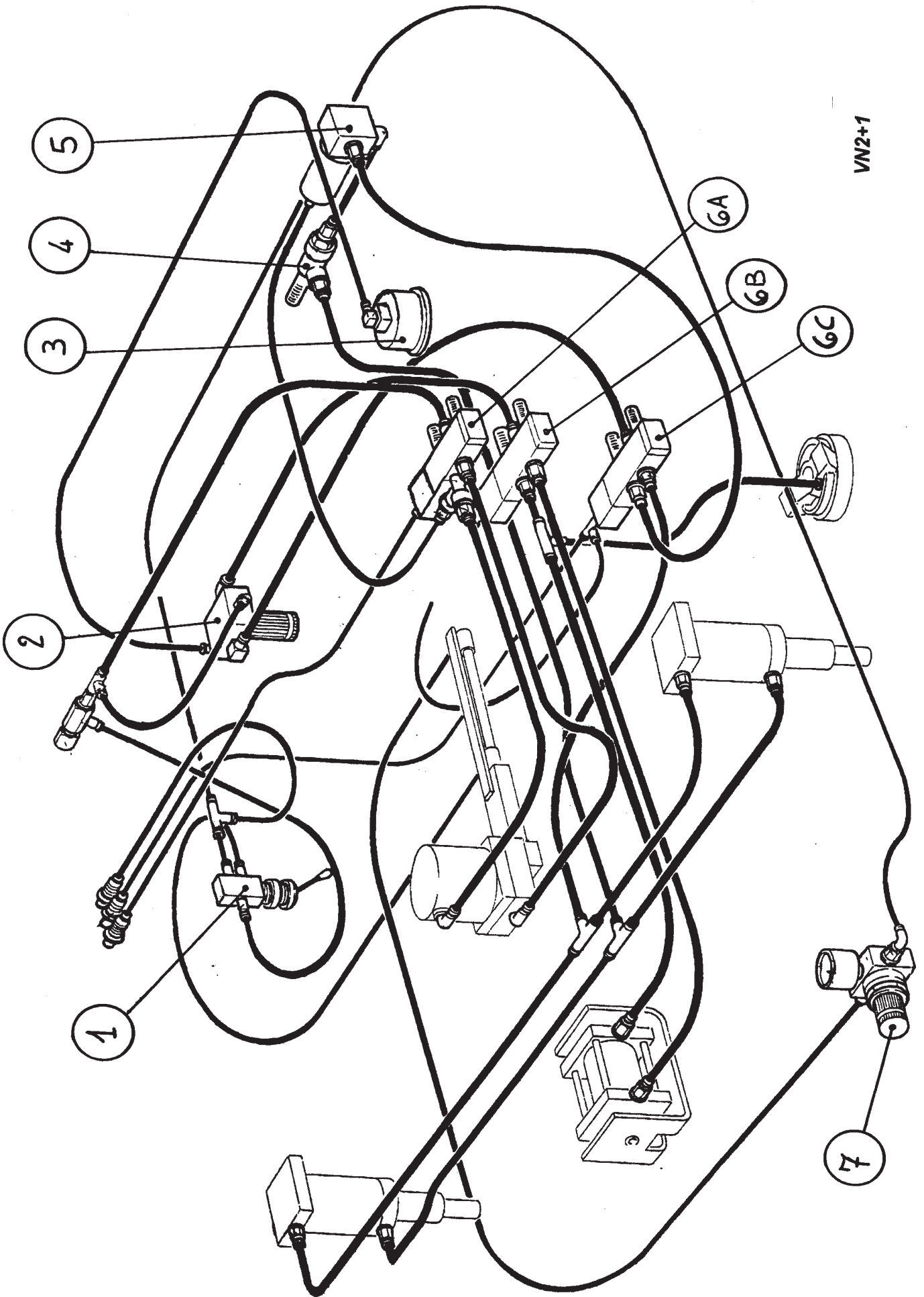

VN2+1

Please Note: Parts in bold red text are available for purchase online at: www.itwamp.com

Mitre Mite® VN 2+1

Pneumatic Parts List

Ref.	Item	Qty	Description
1	732140001	1	Pneumatic Loading Valve (PLV)
2	735630002	1	Pressure Regulator 1/8" 0-8 Bar
3	734230008	1	Pressure Gauge Main
4	732390001	1	Exhaust Valve 1/8"
5	735130006	1	Soft Clamp Regulator
6A	732440001	1	Control Valve
6B	732440001	1	Control Valve
6C	732440001	1	Control Valve
7	735630002	1	Pressure Regulator 1/8" 0-8 Bar

SCHEME C - Plates location

CAUTION: KEEP THE FINGERS AWAY

CAUTION!
FOR YOUR SECURITY
DISCONNECT THE AIR
SUPPLY BEFORE REPLACING
THE V-NAIL CLAW HEAD OR
ANY MAINTENANCE OPERATION

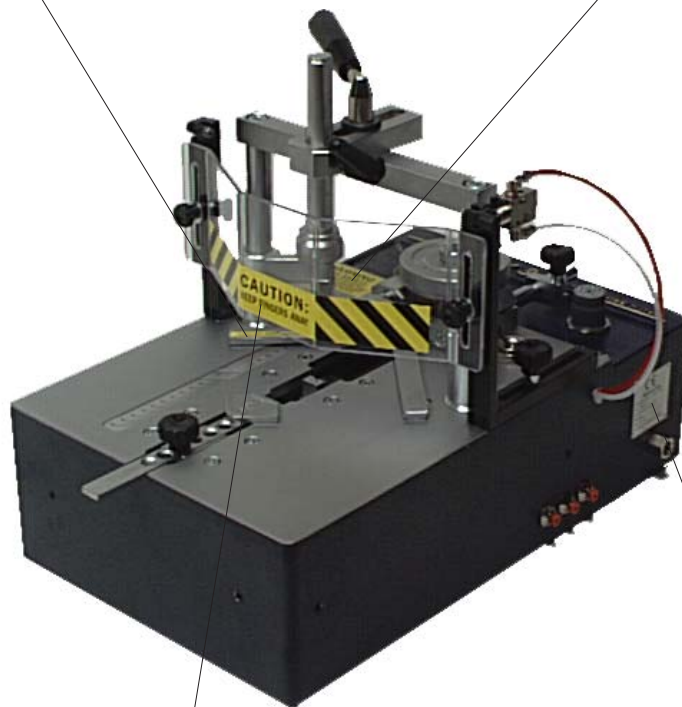

○ **CE** ○
Alfamacchine
Via dell'Artigiano, 12 Forlì ITALY
Tipo Minigraf 3
Anno di costruzione 199
Matricola _____
Peso 28 Kg.
Alimentazione pneumatica 5-7 BAR
○ ○

CAUTION:
KEEP FINGERS AWAY

SCHEMES D - SHARPENING TABLE

	SOFT WOOD			HARD WOOD		
	A	B	C	D	E	F
<i>Height</i> mm	Very soft wood	Soft wood	Averaged soft wood	Averaged hard wood	Hard wood	Very hard wood
H 3* mm	HPT	HPT	HPT	HPT	HPT	HPT
H 5* mm	HPT	HPT	HPT	HPT	HPT	HPT
H 7 mm	SPT	SPT	HPT	HPT	HPT	HPT
H 10 mm	SPT	SPT	HPT	HPT	HPT	HPT
H 12 mm	SPT	SPT	HPT	HPT	HPT	HPT
H 15 mm	SPT	SPT	HPT	HPT	HPT	HPT

SPT Suitable for soft wood such as: Thailand and Asian South-East wood, Cedar, Pine, Bass, Banak, Obeche, Poplar
Other materials: Cellular, Polystyrene, Vertical Grain MDF

HPT Suitable for soft wood such as: Thailand and Asian South-East wood, Cedar, Pine, Bass, Banak, Obeche, Poplar , polystyrene, pvc

HPT Suitable for soft wood such as: Oak, Ash, Hickory, Pecan, Maple, Cherry, Ramin
Other materials: Horizontal grain MDF

HDF Suitable for horizontal Grain MDF & HDF

	In order to stack 2 or more V-nails per junction, use V-nails coded HPT OR HDF
---	---